

User's instructions

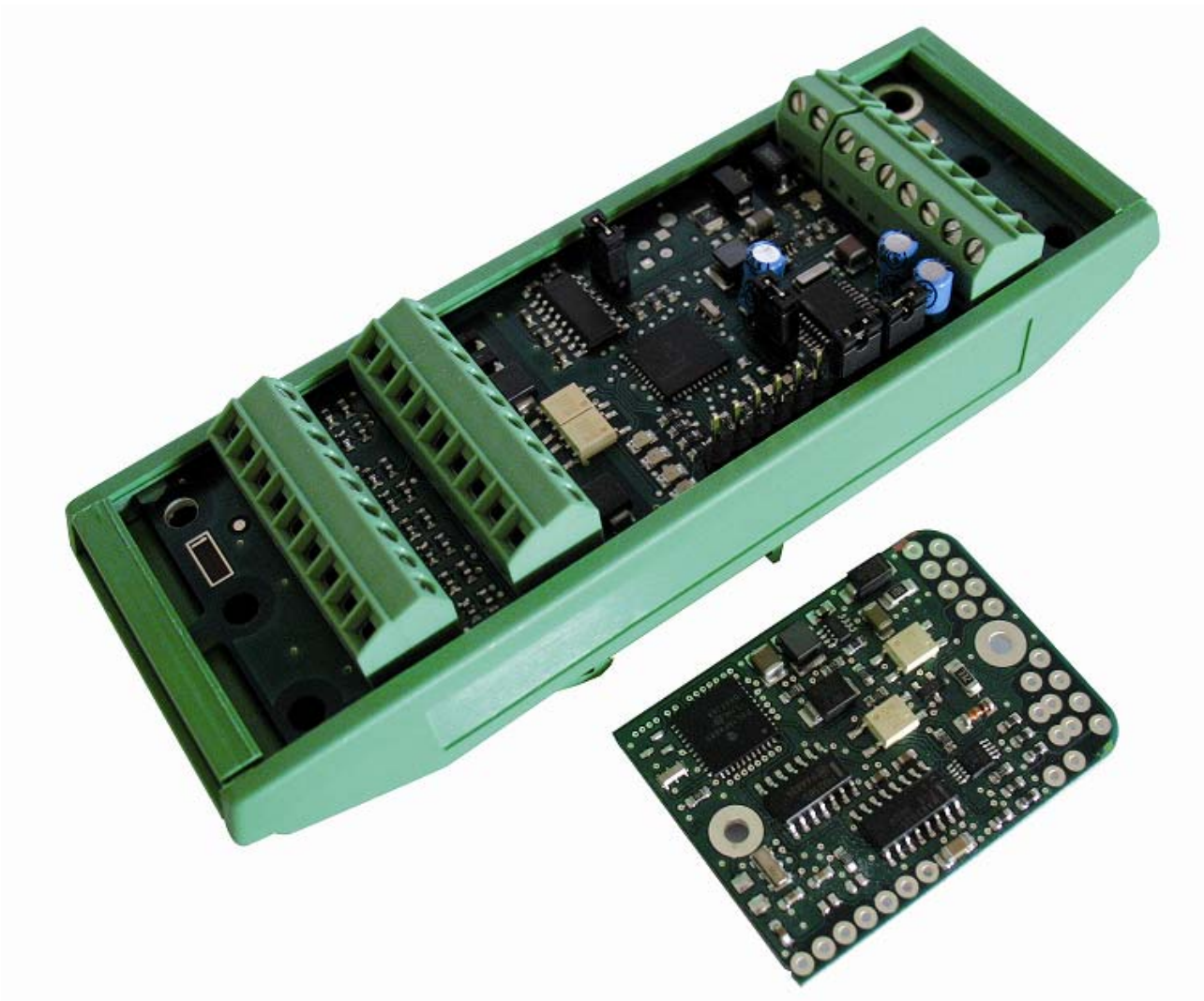

Document revisions		
version	date	description
A	06/10	- creation
B	04/12	- Communication interface connections

/

1 GENERAL PRESENTATION :	4
1.1 Dimensions :	4
1.1.1 eNod3-T :	4
1.1.2 eNod1-T :	5
1.2 General characteristics :	5
2 INTERFACES	7
2.1 Connection to power supply :	8
2.2 Load cell(s) connections :	8
2.3 Connection of digital Inputs:	9
2.4 Connection of digital Outputs:	10
2.5 Communication interfaces :	11
3 USE IN LEGAL FOR TRADE APPLICATIONS :	12
3.1 Introduction :	12
3.2 Legal for trade parameters :	12
3.3 Sealing :	12
3.3.1 Physical sealing :	12
3.3.2 Software sealing :	12
3.4 Specific requirements :	12
4 COMMUNICATION :	13
4.1 Interfaces :	13
4.1.1 RS232 – RS485 – RS422 Interfaces :	13
4.1.2 CAN Interface :	13
4.2 Communication protocols :	13
4.2.1 ModBus RTU :	13
4.2.2 SCMBus :	13
4.2.3 Fast SCMBus format :	14
4.2.4 CANopen® :	14
5 TRANSMITTER OPERATING MODE :	14
5.1 Measurement reading request :	14
5.1.1 Single measurement transmission :	14
5.1.2 Continuous measurement transmission :	14
6 CALIBRATION :	14
6.1 Calibration types :	14
6.2 Non-linearity correction	15
7 INPUTS FUNCTIONING :	16
7.1 Inputs assignement :	16
7.2 Description :	16
7.2.1 None :	16
7.2.2 Tare :	16
7.2.3 Zero :	16
7.2.4 Transmit measurement (Fig. 4) :	16
7.2.5 Measurement window (Fig. 5) :	17
7.2.6 Clear :	17
8 OUTPUTS FUNCTIONING :	17
8.1 Outputs assignement :	17
8.2 Description :	17
8.2.1 Set point :	17
8.2.2 Motion :	17
8.2.3 Defective measurement :	17
8.2.4 Input image :	17
8.2.5 Level on request :	17
9 SET POINTS:	18
10 FILTERS :	18

1 GENERAL PRESENTATION :

eNod1-T & eNod3-T provide an economic high performance solution to transform any strain gauge sensor into a smart digital system. **eNod1-T & eNod3-T** include an advanced operating mode for control of static and dynamic process:

eNod1-T & eNod3-T are equipped with RS485/422, RS232 and CANbus interfaces supporting **ModBus-RTU**, **SCMbus** and **CANopen®** protocols. Each module is also provided with 2 digital inputs and 2 digital outputs, authorizing synchronization of functions with automation and alarm management. **SCAIME** provides the **eNodView** software to facilitate installation of **eNod1-T & eNod3-T** to set parameters and calibrate the measurement system, for acquisition of measurements and simulation of digital filters.

1.1 Dimensions :

1.1.1 eNod3-T :

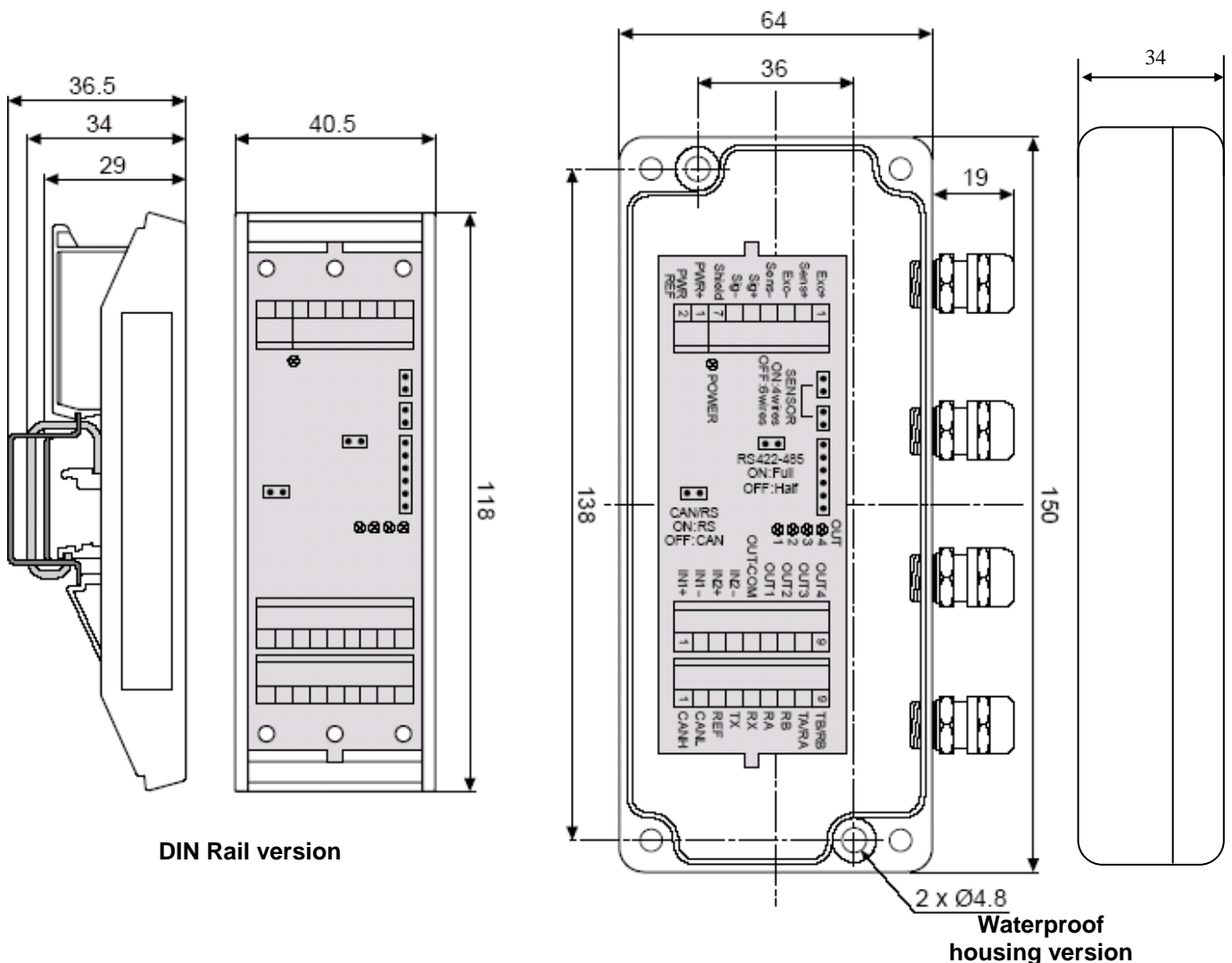

With waterproof housing version a connecting cable with a shield grounded on both sides should be used to connect peripheral devices and **eNod3-T**.

Cable gland is provided with an inside contact spring for an easy and safe EMC connection of shield cable and housing.

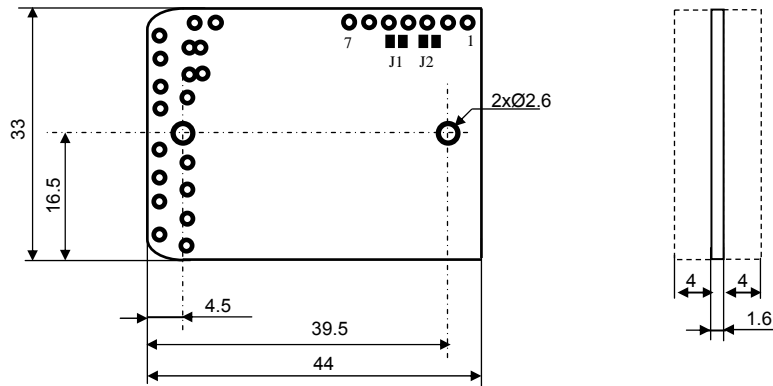
1.1.2 **eNod1-T**:

1.2 General characteristics :

Power supply		Unit
power supply voltage	10 28	V _{DC}
max consumption	70 with 350Ω load cell 120 with 80Ω load cell	mA
Temperature range		
storage temperature	-25...+85	°C
operating temperature	-10...+40	°C
Load cell		
impedance (complete bridge)	> 80	Ω
connection	4 or 6 wires	
load cell power supply	5 ± 5%	V _{DC}
Communication		
RS232		
RS 485/422	eNod3-T : Half or full-duplex	
RS485	eNod1-T : Half-duplex	
RS baud rate	9600...115200	bauds
Can 2.0A	20....1000	kbauds
Logical inputs		
number	2	
type	optocoupler	
low-level voltage	0 3	V _{DC}
high-level voltage	9 28	V _{DC}
current at high level	10mA @ 24V	mA
insulation voltage	2500	V _{rms}
Logical outputs		
number	2	
type	opto-insulated static relays	
max current @ 40°C	0.4	A
max voltage in open state	55	V
resistance in ON state	2	Ω
insulation voltage	2500	V _{rms}

Metrological characteristics		
analog input signal range	± 7.8	mV/V
typical temperature offset drift	1,5	ppm/°C
typical slope temperature effect	2	ppm/°C
max linearity error	0.003	%
A/D conversion rate	6.25 ... 1920	meas./s
Legal for use metrological characteristics		
Class	III or IIII	
Maximum number of verification scale divisions	6000 for class III 1000 for class IIII	
Minimum voltage division per verification scale division (ΔU_{\min})	0.5	μV
Maximum voltage for weighing range	39	mV
Minimum impedance for the load-cell	80	Ω
Maximum impedance for the load-cell	1500	Ω
Value of factor P_i	0.5	
Programmable functions		
acquisition of zero, taring, zero tracking		
physical or theoretical calibration		
slope correction		
non-linearity polynomial correction		
low-pass, band-stop and self-adaptive digital filters		
set points management		

2 INTERFACES

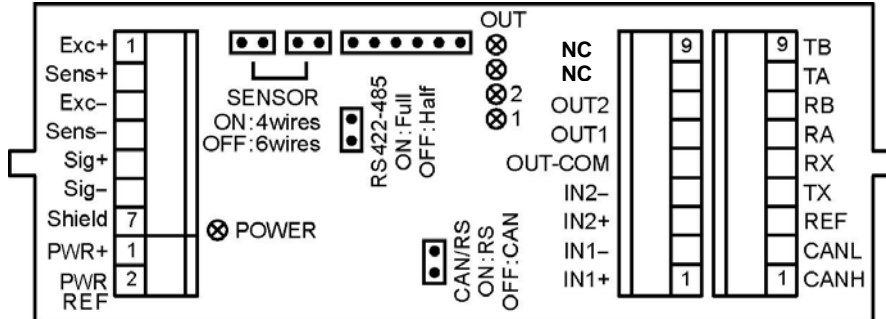
eNod3-T:



eNod1-T

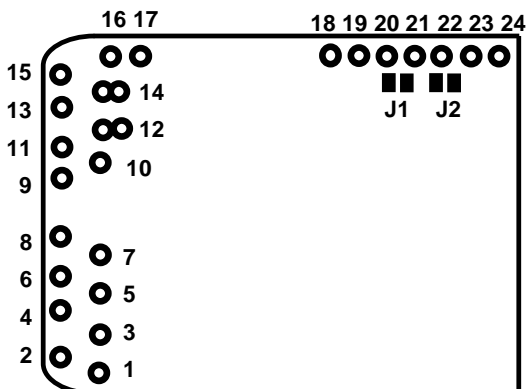

N°	Fonction	N°	Fonction	
1	PWR	PWR + (10 to 28Vdc)	CAN	CANH
2		PWR Ref		CANL
3	OUT	OUT _{COM}	RS485	TB/RB (RS485)
4		OUT1		TA/RA (RS485)
5		OUT2		RX (RS232)
6		N.U.	RS232	TX (RS232)
7		N.U.		Load-cell
8	IN	IN - COM	SENS -	
9		IN2+	SENS +	
10		IN1+	SIG -	
			SIG +	
			EXC -	
			EXC +	
11	REF Communication	24		

2.1 Connection to power supply :

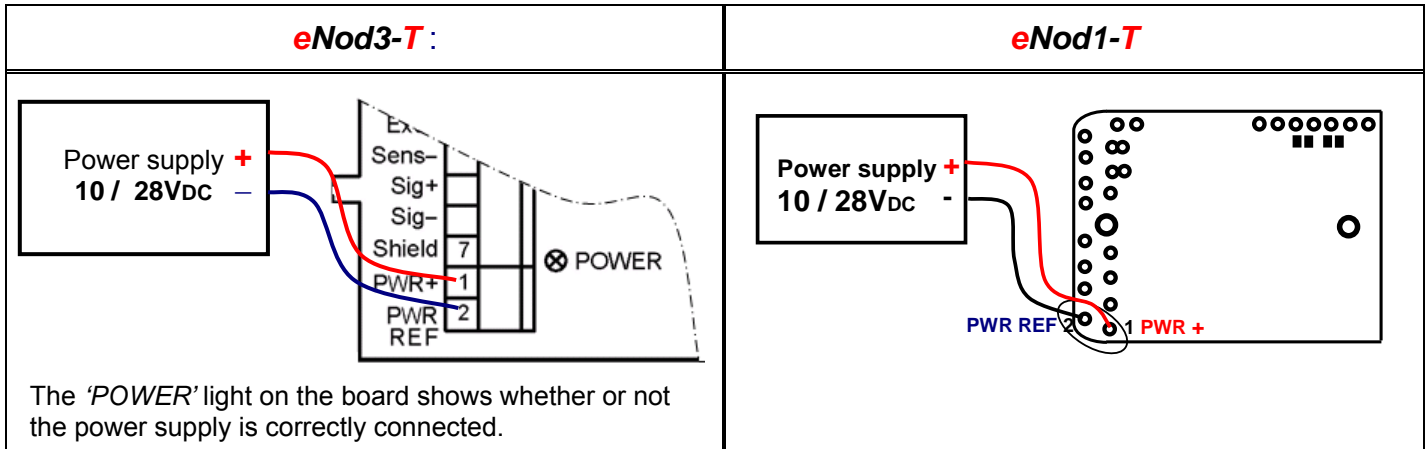

2.2 Load cell(s) connections :

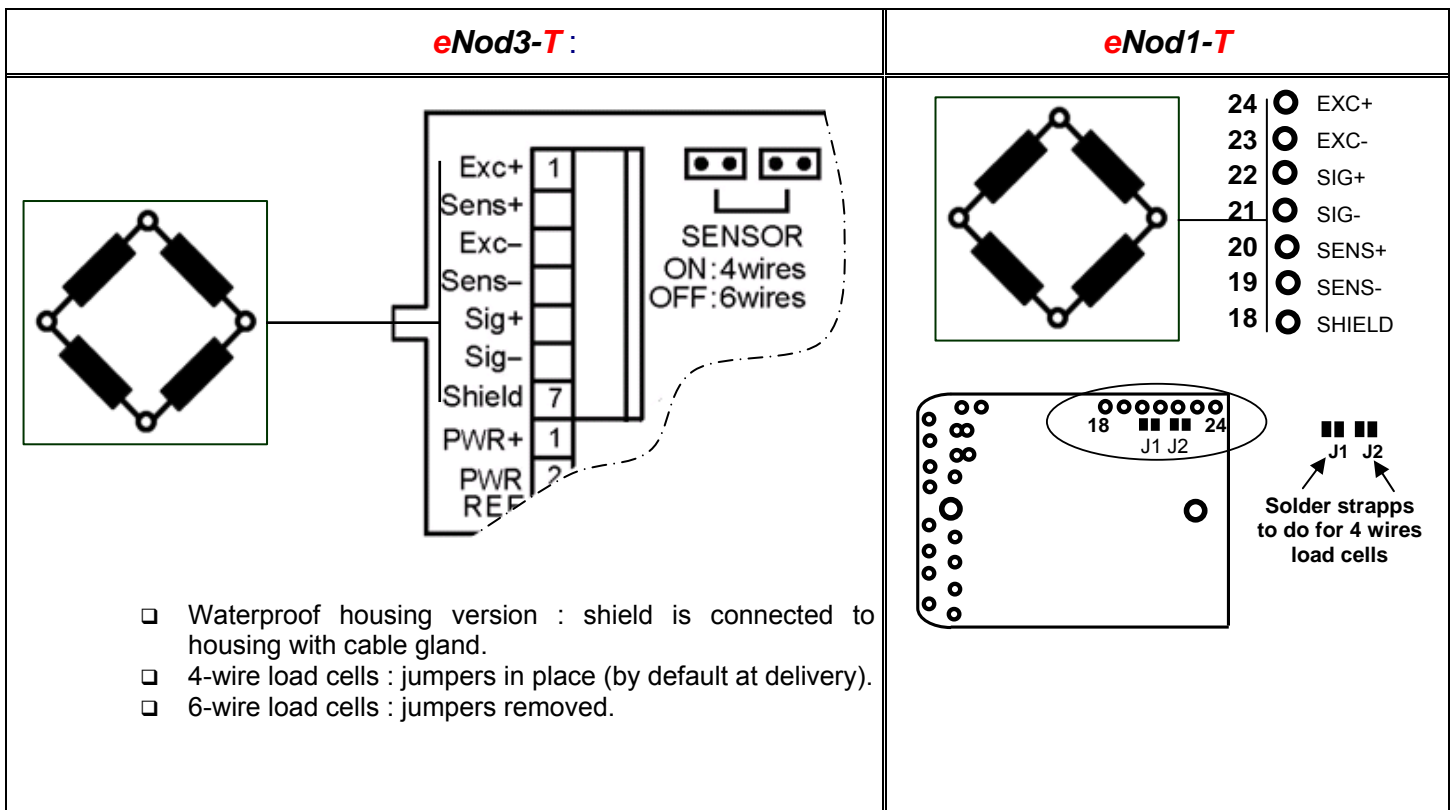

eNod3-T & **eNod1-T** power supply to the load cells (5 V_{DC}).

eNod3-T & **eNod1-T** allow the use of 4- or 6- wire load cells.

- 4-wire load cells : jumpers in place (**eNod3-T**) or solder strapps on J1 and J2 (**eNod1-T**)
- 6-wire load cells : jumpers removed (**eNod3-T**) or J1 and J2 open (**eNod1-T**)

2.3 Connection of digital Inputs:

Opto-insulated inputs characteristics	
high level : 9 to 28V _{DC} Consumption : 10mA @ 24V _{DC} low level : 0 to 3V _{DC}	
eNod3-T:	eNod1-T
Connection to a detector :	
Connection to a push button (PB)	

2.4 Connection of digital Outputs

Opto-insulated outputs characteristics	
max current @ 40°C : 0.4 A max voltage in open state : 55V _{DC} or 38V _{AC} resistance in the ON state : 2 Ω insulation voltage : 2500 Vrms	
eNod3-T :	eNod1-T
<p>€ A light is assigned to each output</p>	
Examples of connection	Examples of connection

2.5 Communication interfaces :

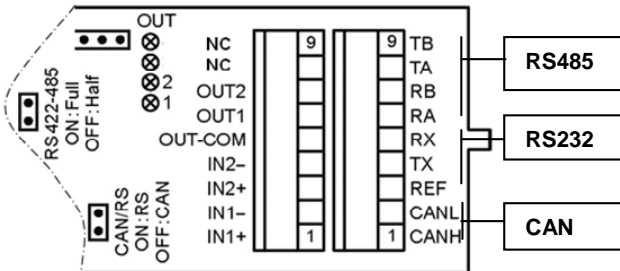
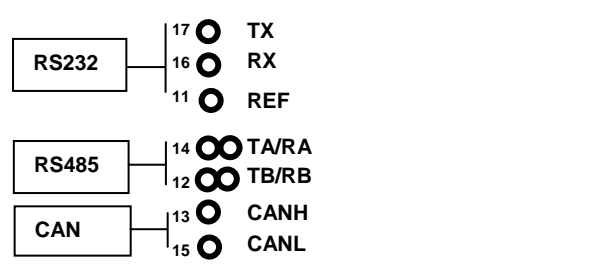
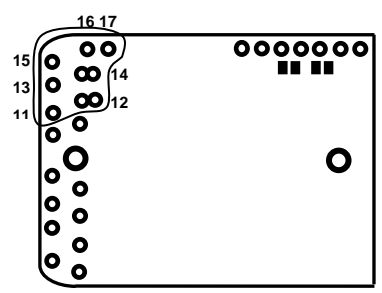
eNod3-T :	eNod1-T
 <p>For a RS communication (485 or 422 or 232) the CAN / RS jumper must be in place on corresponding pins (by default at delivery).</p> <p>The connection to the RS 485 / RS 422 interface is made through TA, TB and RA, RB connections on the 9-pins connector. (TA = direct transmission, TB = inverse transmission, RA = direct reception, RB = inverse reception).</p> <p>For an RS485 (half duplex) communication, just connect the TB and TA pins and remove the corresponding jumper (OFF).</p> <p>For an RS422 or RS485 full-duplex communication, use the four TB, TA, RB and RA pins. The corresponding jumper must be in place (ON) (which is the default case on delivery).</p> <p>The RS232 interface is connected using TX, RX and REF connections on the 9-pin connector.</p> <p>For a CAN communication the CAN / RS jumper must be removed (OFF) on corresponding pins. The CAN interface is connected using the CANH, CANL and REF (not mandatory) connections on the 9-pin connector.</p> <p>Note : Jumper presence is read at power on.</p>	  <p>eNod1-T is equipped with three digital dialog interfaces. The dialog interfaces are : RS232, RS485 and CAN, they are working this way :</p> <ul style="list-style-type: none"> - After power-up, eNod1-T starts by default using CANopen® protocol. - If eNod1-T receives a valid RS485 or RS232 frame (ModBus-RTU or SCMBus), it automatically switches into this communication mode. Recovering CAN communication is done by resetting eNod1-T (<i>hardware or software reset</i>). <p>Note : RS485 communication is half-duplex only.</p>
<ul style="list-style-type: none"> <input type="checkbox"/> Communication interfaces are not electrically isolated from power supply. Depending on installation configuration, the usage of optocouplers or other galvanic isolation devices is strongly recommended. <input type="checkbox"/> Note: If multiple elements connected to the CAN or RS 485 bus are using power supplies with different reference levels (0V); the problem mentioned above can occur. 	

3 USE IN LEGAL FOR TRADE APPLICATIONS :

3.1 Introduction :

eNod3-T waterproof housing version complies with **LNE-17362 Part Certificate dated November 23, 2009**, following **OIML R76**. It can be used as a module intended to be integrated in a weighing instrument for legal for trade uses.

3.2 Legal for trade parameters :

See relative sections in the following documents :

- **ModBus RTU communication** Ref. 165784
 - ⇒ § : Metrological version number
 - ⇒ § : Legal for trade
 - ⇒ § : Status register
- **SCMbus communication** Ref. 165786
 - ⇒ § : Legal for trade
 - ⇒ § : Transmit measurement, status bytes
- **communication CANopen®** Ref. 165788
 - ⇒ § : Legal for trade settings
 - ⇒ § : Current measurement
 - ⇒ § : Current measurement status

3.3 Sealing :

The module **eNod3-T** has a physical sealing device and a software sealing device.

3.3.1 Physical sealing :

The physical sealing comprises either two self-adhesive stickers self-destructive when removed or a device with sealing screws with lead and sealing wire.

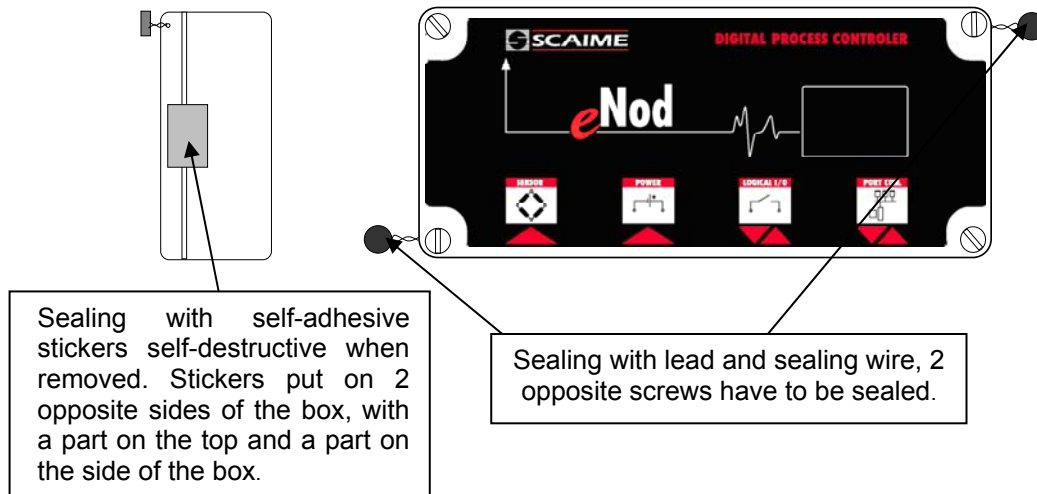

3.3.2 Software sealing :

The value of the event counter as well as the CRC value may be displayed on the weighing instrument. The weighing instrument has a marking area where the values of the event counter and of the CRC recorded after the last official verification are recorded. These marked values shall be identical to these displayed on the terminal. When these values do not match, this part of the sealing device is considered as broken.

3.4 Specific requirements :

The legal metrological software version may be displayed on the terminal.

There are also some characteristics in the status related to measurements that need to be displayed on the terminal too.

4 COMMUNICATION :

4.1 Interfaces :

4.1.1 RS232 – RS485 – RS422 Interfaces :

Available baud rates :

- 9600 bauds
- 19200 bauds
- 38400 bauds
- 57600 bauds
- 115200 bauds

When using RS422 and RS485 interfaces and to avoid signal reflection phenomena that may lead to communication errors, the bus might be closed through termination resistors. 120-ohm resistors should be placed at each bus extremity.

Choice of address, baud rate and communication protocol (**SCMBus** or **ModBus-RTU**) can be done by software programming.

By default at delivery baud rate is 9600 bauds and address is 01_H.

4.1.2 CAN Interface :

Available bit rates :

- 20000 bauds
- 50000 bauds
- 125000 bauds
- 500000 bauds
- 800000 bauds
- 1000000 bauds

So as to avoid signal reflection phenomena that may lead to communication errors, the bus **must** be closed through termination resistors. 120-ohm resistors should be placed at each bus extremity.

By default at delivery, bit rate is 125000 bauds and the node number is 01_H.

4.2 Communication protocols :

eNod1-T & eNod3-T can communicate using several protocols :

- **ModBus RTU**
- **SCMBus** standard format or fast format.
- **CANopen®**

⇒ Switching from the **SCMBus** protocol to the **ModBus-RTU** protocol (and reciprocally) can be done by software programming.

- 1) send the corresponding command
- 2) send the 'storage in EEPROM' command
- 3) **reset** (hardware or software) the device.

⇒ Switching from **SCMBus/ModBus-RTU** protocol to **CANopen®** protocol (and reciprocally) can be done as following :

- **eNod3-T** : by setting or removing the appropriate jumper, and then by making a **reset**.
- **eNod1-T** : After power-up, **eNod1-T** starts by default using **CANopen®** protocol.

If **eNod1-T** receives a valid RS485 or RS232 frame (**ModBus-RTU** or **SCMBus**), it automatically switches into this communication mode. Recovering **CAN** communication is done by resetting **eNod1-T** (hardware or software reset).

RS485 and **RS232** interfaces must not be connected simultaneously.

4.2.1 ModBus RTU :

See the description of the different communication frames in the document : **ModBus-RTU communication** Ref. 165784

4.2.2 SCMBus :

See the description of the different communication frames in the document : **SCMBus communication** Ref. 165786.

The **SCMbus** protocol has got similarities with **Modbus-RTU**. It is based on the master/slave structure however it allows to transmit measurements continuously without collision management on the line.

The measurements transmission frequency depends on the serial baud rate, thus transmitting 100 meas/s is impossible at less than 19200 bauds. For fast measurement transmissions, use the **fast SCMbus format** with wich 1200 meas/s can be expected at 115200 bauds.

Other methods of transmitting information without any master request :

- Measurement transmission triggered by a digital input.
- Physical calibration procedure : automatic transmission when a step in the process is complete.

4.2.3 **Fast SCMbus format :**

The **Fast SCMbus** format is particularly useful for measurement acquisition at the highest rate, for example in order to analyze dynamic phenomena. This format should only be used for point-to-point operation in full-duplex.

So as to optimize the speed, in addition to using the **fast SCMbus format**, it is preferable to configure **eNod1-T** or **eNod3-T** in '**non-processing transmitter**'. In this operating mode, filters are disabled, set points are not managed and there is no polynomial linearization

4.2.4 **CANopen® :**

eNod1-T et **eNod3-** supports **CANopen®** communication protocol and is compliant with 'CiA® Standard V301'. Refer to the description note : **CANopen® communication** Ref. 165788.

5 **TRANSMITTER OPERATING MODE :**

This basic operating mode consists in transmitting measurements on the bus, possibly after configuring them, filtering them and comparing them to set point levels.

Measurements can be transmitted individually regardless of the communication protocol or continuously at a defined frequency in **SCMbus** (standard or fast format) or **CANopen®** protocols.

Functioning may be unipolar (positive analog signal only) or bipolar (positive or negative analog signal).

5.1 **Measurement reading request :**

5.1.1 **Single measurement transmission :**

Regardless of the communication protocol in use.

The request can apply to :

- gross measurement
- net measurement
- tare value
- measurement in A/D converter points.

5.1.2 **Continuous measurement transmission :**

This is possible using **standard or fast SCMbus format**, the transmission can be started by a serial command and another one allows stopping it. Measurements are transmitted at a period defined in ms by the '**sampling period**' setting.

The request can apply to

- gross measurement
- net measurement
- measurement in A/D converter points

□ **Note** : This is very similar to operation of '**Measurement window**' through an input command.

CANopen® protocol also allows defining a period at which measurements are sent on the bus without any master request.

6 **CALIBRATION :**

6.1 **Calibration types :**

There are different possible calibration types :

- ⇒ Physical calibration using known references on the load cell. This type of calibration can be done with 1, 2 or 3 known loads.
- ⇒ Theoretical adjustment by setting the load cell sensitivity and a corresponding capacity.

⇒ Correction of the initial calibration value with a coefficient.

6.2 Non-linearity correction

For an installation with a non-linearity :

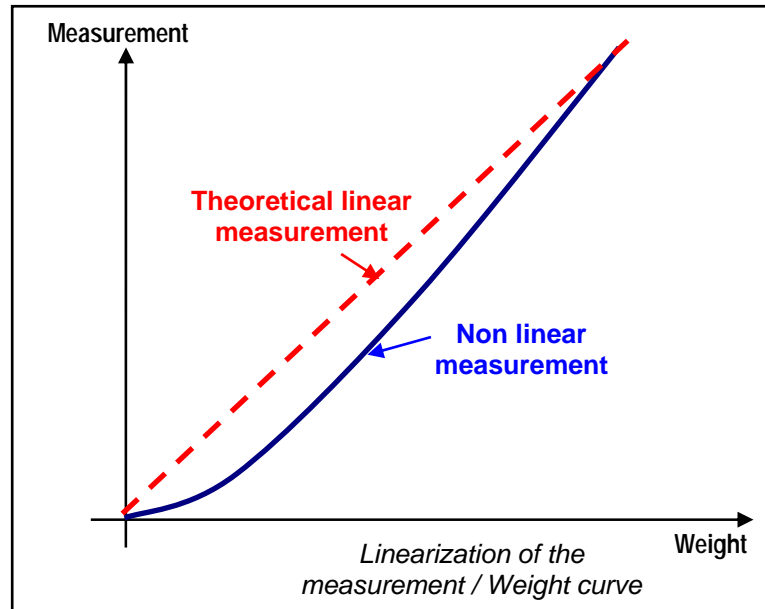

Fig. 1

The linearization formula is as follows :

$$\text{Corrected measurement} = \text{Meas} - A (\text{Meas})^2 - B(\text{Meas}) - C$$

where Meas = current measurement

The three A, B and C coefficients can be determined using **eNodView** software.

7 INPUTS FUNCTIONING :

Each input can work in positive or negative logic individually. A debounce time attached to both inputs can be adjusted.

7.1 Inputs assignement :

Fonction
none
tare
zero
transmit measurement
measurement window
clear

7.2 Description :

7.2.1 *None* :

Inputs have no effect.

7.2.2 *Tare* :

One or the other or both inputs can be assigned to the tare function. The tare acquisition is conditioned by a stability criterion that can be changed or inhibited.

Depending on the chosen logic (positive or negative), the tare is triggered by a rising or a falling edge.

7.2.3 *Zero* :

One or the other or both inputs can be assigned to the zero function.

A new volatile zero value is acquired only if its value is within $\pm 10\%$ range of the specified capacity for a usage out of legal for trade and $\pm 2\%$ for legal for trade application. The zero acquisition is conditioned by a stability criterion that can be changed or inhibited.

Depending on the chosen logic (positive or negative), the zero is triggered by a rising or a falling edge.

7.2.4 *Transmit measurement (Fig. 4)* :

This is only possible using **standard or fast SCMBus** format or **CANopen®** protocols.

The request can apply to :

- gross measurement
- net measurement
- measurement in A/D converter points

A single measurement is transmitted per rising or falling edge (depending on the configured logic) on the input signal.

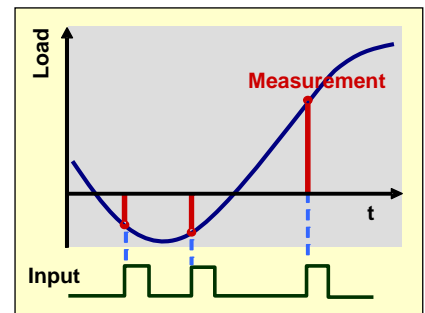

Fig. 4

7.2.5 Measurement window (Fig. 5) :

This is only possible using **standard or fast SCMBus**. The request can apply to :

- gross measurement
- net measurement
- measurement in A/D converter points

While the input is kept at the right level, a series of measurements are transmitted at the period defined by the 'sampling period' setting.

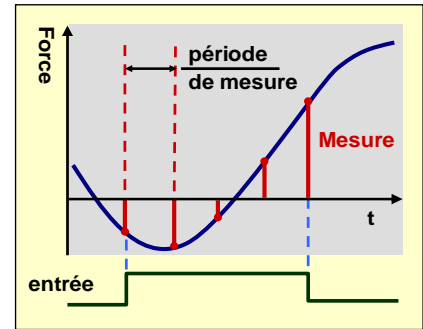

Fig. 5

7.2.6 Clear :

Cancels current tare (same functioning as 'cancel tare' command).

8 OUTPUTS FUNCTIONING :

Each output can work individually in its own logic.

8.1 Outputs assignement :

Fonction
set point
motion
defective measurement
input image
level on request

8.2 Description :

8.2.1 Set point :

The outputs can be assigned to configurable set points Output 1 is assigned to set point 1 , output 2 to set point 2.

8.2.2 Motion :

The outputs can be assigned to copying measurements stability.

8.2.3 Defective measurement :

The outputs can be assigned to copying the measurements faults. These faults are also coded in the status word :

- * Signal outside the converter analog input range
- * Signal outside the capacity on the positive side
- * Signal outside the capacity on the negative side

8.2.4 Input image :

Outputs can be assigned to copying inputs state, either using the same logic or inverting the input state (negative logic). Output 1 is assigned to input 1 and outputs 2 to input 2.

8.2.5 Level on request :

Activation of outputs is ordered with communication commands. When an 'output activation' command is received, the output remains activated until :

- The reception of an 'output inhibition' command if the output activation duration is equal to 0.
- The specified activation duration has elapsed

9 SET POINTS:

Set points are characterized by a high and a low value.
 They are two operating modes :

- **hysteresis.**
- **window.**

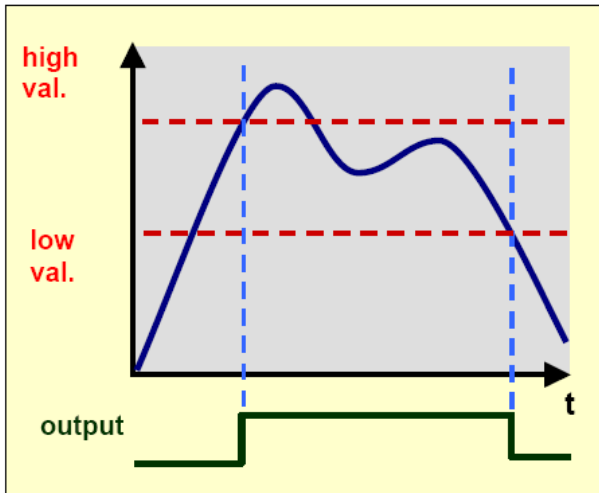

Functioning in hysteresis
 Fig. 2

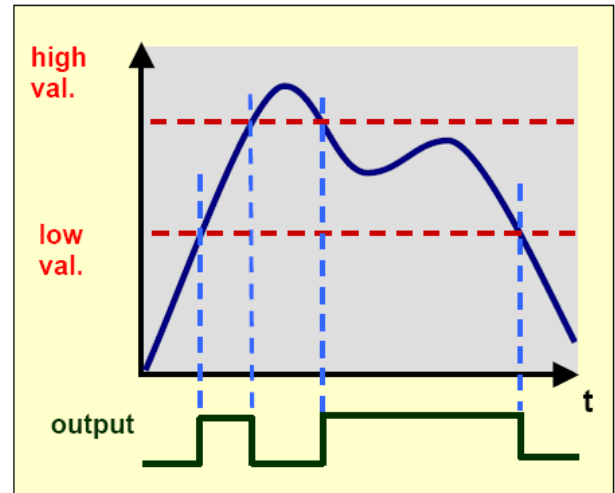

Functioning in window
 Fig. 3

The low and high values of these set points may be assigned either to :

- **gross measurement**
- **net measurement.**

10 FILTERS :

There are four available filtering levels :

- * filtering related to the A/D conversion rate including rejection of the mains frequency (50 or 60 Hz) harmonics.
- * 2nd, 3rd or 4th order low-pass Bessel/Butterworth filter
- * 2nd order band-stop filter
- * self-adaptive filter

- **Filtering related to the A/D conversion rate** : the signal resolution is related to the conversion rate. The conversion rate might be chosen as low as possible, particularly for static applications. For dynamic applications, a compromise must be found between the measurement rate and the low-pass filter cut-off frequency. The **eNodView** software can be used to determine appropriate filter values.

Choose a measurement rate that rejects the mains frequency harmonics according to the place of use, 50 or 60Hz.

- **Bessel or Butterworth type low pass filter** : a low-pass digital filter can be applied as an output of the A/D converter. The filter order is configurable (available values are 2, 3 or 4) and the coefficients that define it depend on the A/D conversion rate, the wanted cut-off frequency and on the chosen order. These coefficients can be easily calculated by **eNodView** software.

- **Band-stop filter** : a 2nd order band-stop filter might be applied as an output of the low-pass filter (if used) or the A/D converter. It allows attenuating the frequencies within a band defined by high and low cut-off frequencies. The coefficients that define it depend on the A/D conversion rate and the wanted cut-off frequencies (that means the frequency band width). These coefficients can be easily calculated by **eNodView** software.

- **Self-adaptive filter** : this filter can be set in cascade after previous filters. It is particularly efficient for static measurements but avoid using it in dynamic or dosing processes. The aim of this filter is to eliminate erratic measurements and to average consistent measurements.